



# Instruction Manual

## Electric Fryers



Model No. 8047D, 8048D, 8049D, 8050D, 8051D  
8066, 8068, 8068FL, 8073, 8073BF, 8075







**GOLD MEDAL<sup>®</sup> PRODUCTS CO.**



10700 Medallion Drive, Cincinnati, Ohio 45241-4807 USA



## SAFETY PRECAUTIONS

	 <b>DANGER</b>
	<p>Machine must be properly grounded to prevent electrical shock to personnel. Failure to do so could result in serious injury, or death. DO NOT immerse any part of this equipment in water. DO NOT use excessive water when cleaning. Keep cord and plug off the ground and away from moisture. Always unplug the equipment before cleaning or servicing. Make sure all machine switches are in the OFF position before plugging the equipment into the receptacle.</p> <p style="text-align: right;">008_051514</p>

	 <b>DANGER</b>
	<p>Improper installation, adjustment, alteration, service, or maintenance can cause property damage, injury, or death. Any alterations to this equipment will void the warranty and may cause a dangerous condition. This appliance is not intended to be operated by means of an external timer or separate remote-control system. NEVER make alterations to this equipment. Read the Installation, Operating, and Maintenance Instructions thoroughly before installing, servicing, or operating this equipment.</p> <p style="text-align: right;">014_020416</p>

	 <b>DANGER</b>
	<p>Never add water to hot oil. When water is added to hot oil a stream explosion may ensue spattering hot oil resulting in serious burns or more seriously hot oil in someone's eyes.</p> <p style="text-align: right;">024_010914</p>

	 <b>DANGER</b>
	<p>Hot oil is dangerous – severe burns can result when hot oil contacts the skin. Hot oil is flammable – keep open flames away from hot oil and its vapors. Keep a fire extinguisher near this unit. Instruct personnel on what to do if there is a grease fire. DO NOT USE WATER ON A GREASE FIRE! Use only fire extinguishers approved for grease, oil, and electric fire.</p> <p style="text-align: right;">002_102214</p>

	 <b>WARNING</b>
	<p>To avoid burns, DO NOT touch heated surfaces. DO NOT place or leave objects in contact with heated surfaces.</p> <p style="text-align: right;">009_092414</p>





# SAFETY PRECAUTIONS (continued)

	<b>⚠ WARNING</b>
	<p>ALWAYS wear safety glasses when servicing this equipment.</p> <p style="text-align: right; font-size: small;">010_010914</p>

	<b>⚠ WARNING</b>
	<p>No user serviceable parts inside. Refer servicing to qualified service personnel.</p> <p style="text-align: right; font-size: small;">011_051514</p>

	<b>⚠ WARNING</b>
	<p>Read and understand operator's manual and all other safety instructions before using this equipment. To order copies of the operator's manual go to <a href="http://gmpopcorn.com">gmpopcorn.com</a> or write to Gold Medal Products Co., 10700 Medallion Drive, Cincinnati, OH 45241 USA 1-(800)-543-0862</p> <p style="text-align: right; font-size: small;">022_060215</p>

	<b>⚠ WARNING</b>
	<p>DO NOT allow direct contact of this equipment by the public when used in food service locations. Only personnel trained and experienced in the equipment operation may operate this operation. Carefully read all instructions before operation.</p> <p style="text-align: right; font-size: small;">012_010914</p>

	<b>⚠ WARNING</b>
	<p>This machine is NOT to be operated by minors.</p> <p style="text-align: right; font-size: small;">007_010914</p>

**Note:** Improvements are always being made to Gold Medal's equipment. This information may not be the latest available for your purposes. It is critical that you call Gold Medal's Technical Service Department at 1-800-543-0862 for any questions about your machine operations, replacement parts, or any service questions. (Gold Medal Products Co. does not assume any liability for injury due to careless handling and/or reckless operation of this equipment.) General images may be used in manual for reference only.



---

# INSTALLATION INSTRUCTIONS

## Inspection of Shipment

After unpacking, check thoroughly for any damage which may have occurred in transit. Claims should be filed immediately with the transportation company. The warranty does not cover damage that occurs in transit, or damage caused by abuse, or consequential damage due to the operation of this machine, since it is beyond our control (reference warranty in back of manual).

## Manual

Read and understand the operator's manual and all other safety instructions before using this equipment. To order copies of the operator's manual go to [gmpopcorn.com](http://gmpopcorn.com) or write to Gold Medal Products Co., 10700 Medallion Drive, Cincinnati, OH 45241 USA 1-(800)-543-0862.

## Model Description

Electric Fryers listed below consist of a Gold Medal Power Head (with tubular element) and a Gold Medal Tank with a drain valve. The Gold Medal Power Head is intended to be used with the appropriate Gold Medal Tank. Reference the Electrical Requirements section for the specific requirements for each unit.

- Model 8047D:** Small Fryer with Item No. 8060 Power Head and 89056 Tank
- Model 8048D:** Small Fryer with Item No. 8061 Power Head and 89056 Tank
- Model 8049D:** FW-9 Shallow Fryer with Item No. 8063 Power Head and 89230 Tank
- Model 8050D:** FW-12 Shallow Fryer with Item No. 8064 Power Head and 89330 Tank
- Model 8051D:** FW-9 Shallow Fryer with Item No. 8062 Power Head and 89230 Tank
- Model 8066:** Hot Shot FW-12 Fryer with Item No. 8067 Power Head and 89330 Tank
- Model 8068:** King Dog Electric Corndog Fryer with Item No. 8067 Power Head and 89330 Tank
- Model 8068FL:** Foot Long King Dog Fryer with Item No. 8069FL Power Head and 89866 Tank
- Model 8073:** King-9 Fryer with Item No. 8074 Power Head and 89857 Tank
- Model 8073BF:** King-9 Fryer (Batter Food) with Item No. 8074BF Power Head and 89857 Tank
- Model 8075:** K-6 Fryer with Item No. 8067 Power Head and 89824 Tank



## Items Included with this Unit



**Dial Thermometer**  
(included in all models)



**15 AMP Receptacle**  
(included with Model 8048D)



**20 AMP Receptacle**  
(included with Model 8049D)

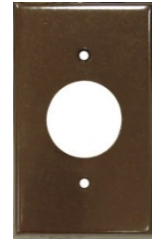

**Cover Plate for 15 or 20 AMP Receptacle**



**Thermometer Bracket**  
(included in all models)

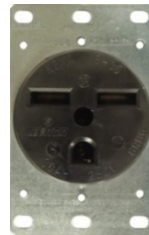

**30 AMP Receptacle**  
(included with Models 8050D, 8068, 8068FL, 8073, and 8073BF)



**50 AMP Receptacle**  
(included with Models 8066 and 8075)

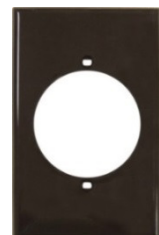

**Cover Plate for 30 or 50 AMP Receptacle**



**Fine Mesh Skimmer**  
(Model 8073BF Only)

**(2) Six Position Skewer Clip Assemblies** (included with Models 8047D, 8048D, 8068, and 8068FL)



## Setup

This unit has been tested at the factory.

1. Remove all packaging and tape prior to operation.
2. Place the fryer in a protected location on a level, sufficiently stable base or table, where it cannot be knocked off. The base or table must be strong enough to support the fryer when full of oil.
3. Remove the tank cover (if provided) and accessories from the unit.
4. For shipping purposes, the Power Head is oriented on the drain side of the tank. To set up for use, orient the power head to sit **centered** of the back rim of the tank (side opposite of the drain) reference image below. Ensure the head is correctly seated on the rim to engage the Power Head Safety Switch. **The unit will not operate if the Safety Switch is not depressed.**

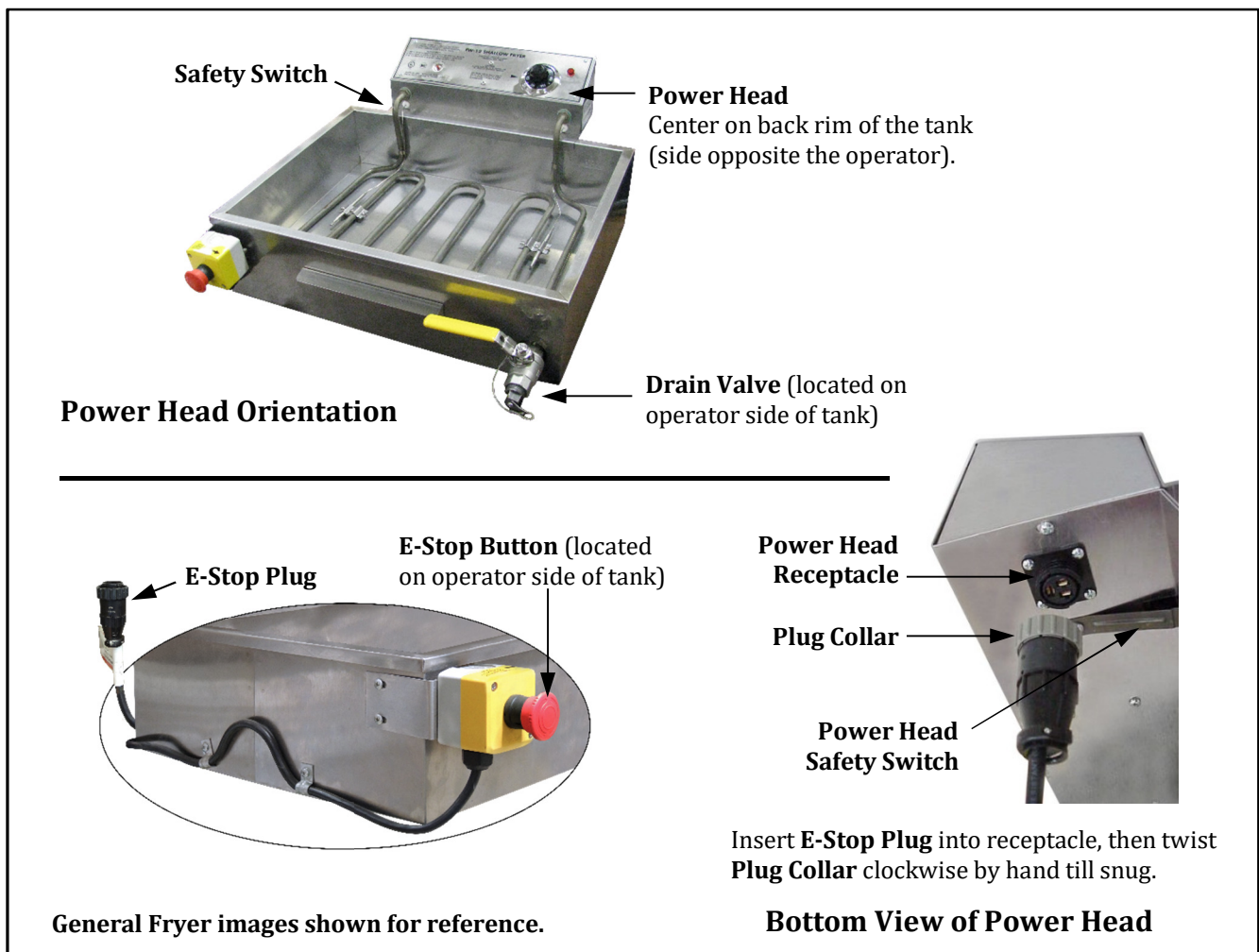

5. Once the power head is positioned, insert the E-Stop Plug securely into the Power Head Receptacle (located on bottom of Power Head), then twist the plug collar clockwise by hand until snug, **DO NOT** overtighten the collar (reference image above).



6. The Drip Pan/Lid (if equipped) may be turned upside down and slid onto the side of the oil tank as a convenient work surface/drip tray, see instructions below.
7. Set the thermometer bracket on the rim of the tank in a convenient location, where the dial thermometer can be inserted and monitored without reaching over the tank.
8. After setup, the unit should be cleaned prior to use (see Care and Cleaning section of this manual).

**Drip Pan/Lid Assembly** (General Fryer images shown for reference.)

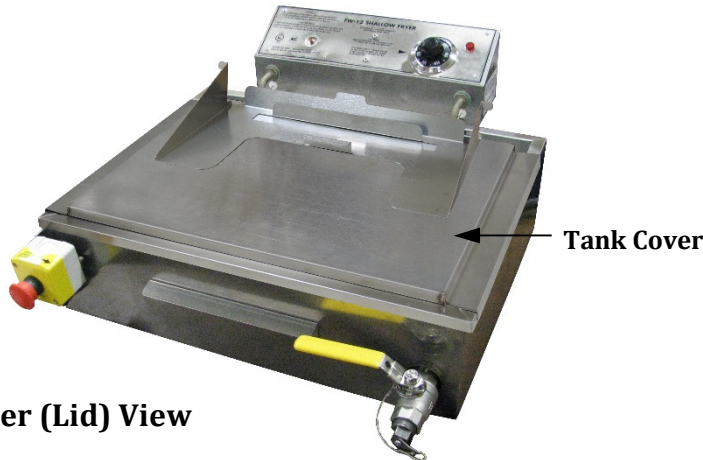

Tank Cover (Lid) View

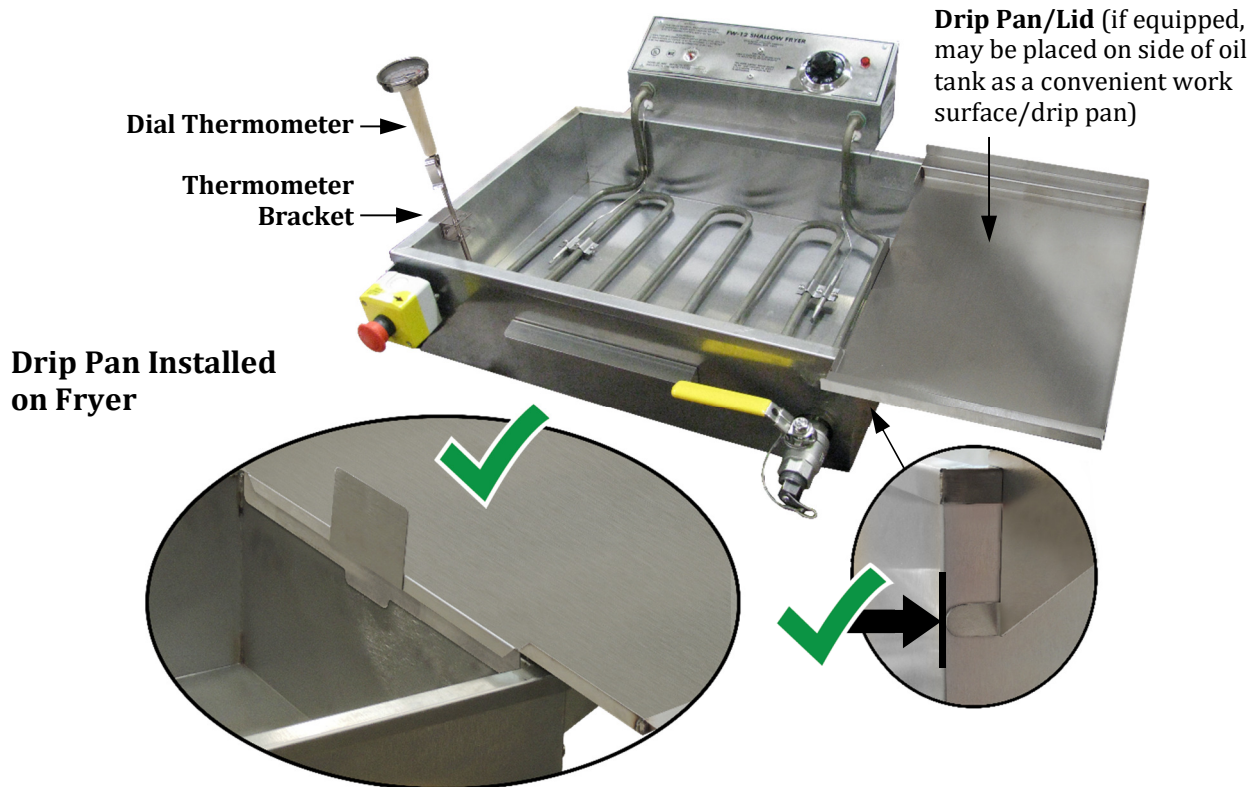

Drip Pan Installed on Fryer



## Electrical Requirements

The following power supply must be provided:

Model	8047D	8048D	8049D*	8050D*	8051D	8066	8068*	8068FL*	8073*	8073BF*	8075
Volts	120	230	230	230	120	230	230	230	230	230	230
Watts	1800	3000	4400	5500	1800	6500	5750	5750	5500	5500	6500
Amps	15	15	20	30	15	50	30	30	30	30	50
Phase	1	1	1	1	1	1	1	1	1	1	1

\* Machines noted above with (\*) are for use on individual branch circuit ONLY.

**DANGER**

Machine must be properly grounded to prevent electrical shock to personnel. Failure to do so could result in serious injury, or death.

**DO NOT** immerse any part of this equipment in water.

**DO NOT** use excessive water when cleaning.

Keep cord and plug off the ground and away from moisture.

Always unplug the equipment before cleaning or servicing.

Make sure all machine switches are in the OFF position before plugging the equipment into the receptacle.

008\_051514

A certified electrician must furnish sufficient power for proper machine operation and install any supplied receptacle. We recommend this equipment be on a dedicated and protected circuit. Failure to wire properly will void the warranty and may result in damage to the machine. It is Gold Medal Products Co.'s recommendation that this machine be plugged directly into a wall outlet. The use of extension cords is not recommended due to safety concerns, and may cause sacrificed and/or reduced performance. Make sure cord is located to prevent a trip hazard or unit upset.

## Before You Plug In Machine

1. Make sure all machine switches are OFF before plugging equipment into receptacle.
2. Make sure wall outlet can accept the grounded plugs (where applicable) on the power supply cord.
3. The wall outlet must have the proper polarity. If in doubt, have a competent electrician inspect the outlet and correct if necessary.
4. **DO NOT** use a grounded to un-grounded receptacle adapter (where applicable).
5. Install unit in a level position.

**CAUTION**

If the supply cord is damaged, it must be replaced by Gold Medal Products Co., its service agent or similarly qualified persons in order to avoid a hazard.

039\_080614







## Important Fire Safety Notice

The building code, in virtually all cities in North America, requires that any fryer with more than a 7 pound oil capacity be operated under a vent hood with “Automatic Fire Extinguisher System”. This system is typically referred to as an “Ansul” or “Kiddie” system.

If this fryer or any fryer outdoors, is operated in a concession trailer, booth, or portable concession stand, building code requirements may apply.

Consult your local fire protection agency for your area’s requirements. Check local fire protection requirements regularly to ensure compliance with local codes and proper operation. Install an automatic fire extinguisher over the fryer and exhaust duct. (Use only fire extinguishers approved for grease, oil, and electrical fire.)

All Gold Medal fryers have a Heat Control and a High Limit Control. The Heat Control sets the working temperature of the oil. The High Limit Control powers down the heat element and protects the operator should the Heat Control fail. The highest quality controls available are used in this product. However, in time, all controls wear out. It is therefore recommended an independent thermometer (capable of 500°F or higher) be immersed in the oil to monitor the oil temperature and make sure the unit is operating properly.

 <b>DANGER</b>	
	<p>Hot oil is dangerous – severe burns can result when hot oil contacts the skin. Hot oil is flammable – keep open flames away from hot oil and its vapors. Keep a fire extinguisher near the fryer. Instruct personnel on what to do if there is a grease fire. <b>DO NOT USE WATER ON A GREASE FIRE!</b> Use only fire extinguishers approved for grease, oil, and electric fire.</p> <p style="text-align: right; font-size: small;">002_020314</p>



## Advanced Safety Measures

### KEEP FRYER AREA CLEAN AND MAINTAINED

- Keep your floors clean and free of grease to prevent slips, accidents, and contact with a hot fryer.
- Keep filters and areas above the fryer clean. Oil-soaked lint or dust can ignite easily and flames spread quickly in an oily environment.

### EDUCATE PERSONNEL

- Ensure all personnel understand the hazards of hot oil. Instruct them on proper actions to take if they suspect any part of the fryer is malfunctioning.

If your fryer malfunctions, have it serviced by Qualified Service Personnel.

**IMPORTANT:** If the fryer starts to smoke or boil abnormally, **cut off power supply** and determine the reason why the fryer is overheating before attempting to use it. There is an Emergency Stop (E-Stop) Switch readily available on the fryer for shutting off the power to the unit. (See Emergency Stop Switch description in the Controls and Their Functions section of this manual.)

- Ensure all personnel understand procedures to follow if the High Limit Control is tripped. (See High Limit Control description in the Controls and Their Functions section of this manual.)
- Educate all personnel on proper procedures to follow if a grease fire should occur. **DO NOT USE WATER ON A GREASE FIRE!** Never direct the extinguisher in a manner that would blow grease out of the tank.

**Ensure a fire extinguisher is readily available to extinguish a grease, oil, and electric fire. Make sure all personnel are properly trained in the use of the fire extinguisher.**

# OPERATING INSTRUCTIONS

## Controls and Their Functions

### TEMPERATURE CONTROL

Turns fryer ON; sets desired temperature.

### PILOT LIGHT

Pilot Light turns ON (indicating the unit is heating) when the Temperature Control is set. The Pilot Light turns OFF when the fryer reaches desired temperature.

### HIGH LIMIT CONTROL

The High Limit Control will power-off the unit in the event of malfunction. The High Limit Control can only be reset after the fryer has cooled to normal operating temperatures. For issues with the High Limit Control tripping, reference the Troubleshooting section of this manual.

### EMERGENCY STOP SWITCH (E-Stop Button)

Push E-Stop Button IN to cut all power to the unit. To reset/turn ON, rotate the E-Stop Button CLOCKWISE and it will release into the operating position, (the button will be in the OUT position). The Emergency Stop Switch MUST be properly plugged into the power head in order for the fryer to operate.

### POWER HEAD SAFETY SWITCH

The Safety Switch is pressed IN when the Power Head is correctly seated on the tank. The unit will not operate if the Safety Switch is not depressed.

### DRAIN VALVE/DRAIN PLUG

The Drain Valve and Drain Plug open to allow efficient draining of the cooking oil from the tank. Always allow hot cooking oil to cool below 140°F before attempting drain the unit.

**Note:** The Drain Valve has a Safety Collar on the handle. Slide the collar up to allow the drain valve handle to be rotated.

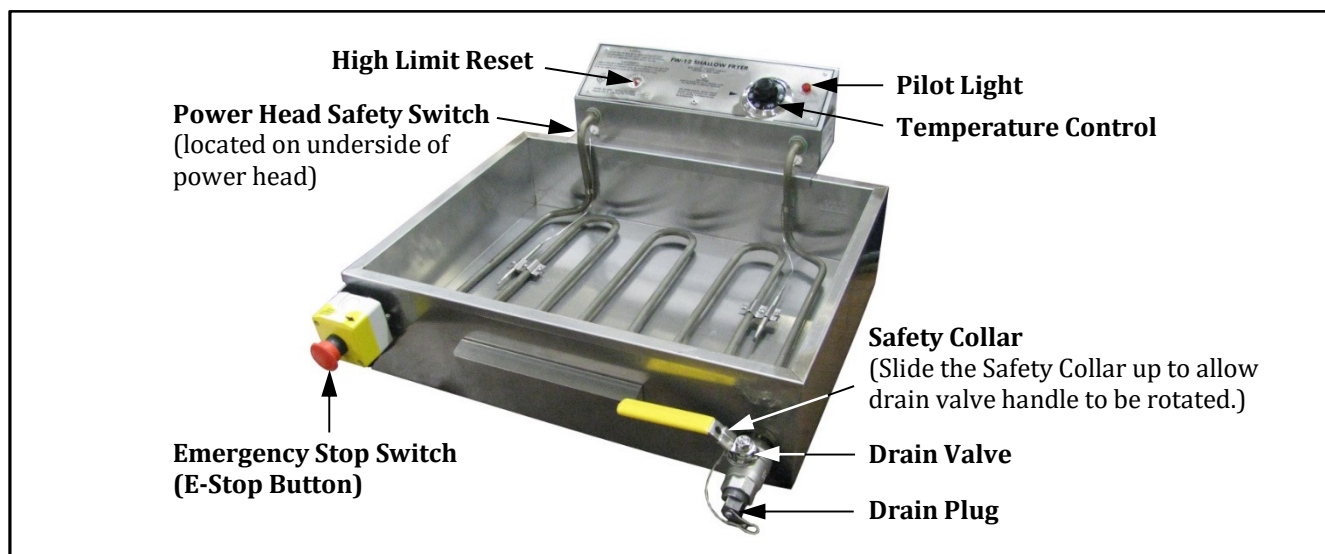



## Tank Preparation

Before operating for the first time, the inside of the fryer tank should be rinsed and thoroughly dried before adding oil. See the Cleaning and Care section of this manual for cleaning instructions.

Prior to each use, check the drain valve to make sure it is securely closed and the drain plug is fully tightened into place. Remove tank cover (if equipped) before turning the power on. **DO NOT** operate this unit with the tank cover in place.

## Filling the Tank with Oil

Initially fill the tank to the minimum oil fill line (fill lines are located on the interior side and rear walls of the tank). **DO NOT** operate this unit with the cooking oil below the minimum oil level.

**IMPORTANT:** Cooking oil expands upon heating. To safely bring the oil level up to the maximum fill level, carefully add additional increments of oil as it heats until it reaches the maximum fill line. **DO NOT** over fill the tank, as overfilling could result in a dangerous situation.

**Hot oil is dangerous** - be sure you have thoroughly read the Safety Precautions of this manual.

**DO NOT allow water to contact oil.** Only cook product intended for this appliance. Do not attempt to cook products with high water content or with surface moisture present. Do not operate in the rain or near any source of water. Failure to keep water away from oil may result in explosion and severe burns. Make sure appliance is completely dry after cleaning, including inside any drain valves.

## Important Operating Information and Quality Control Tips

- Don't overheat. Don't fry if the oil temperature exceeds 400°F.
- Don't waste money. Use only high quality heavy duty frying shortening.
- Don't fry food in broken-down frying shortening. Broken down oil is thinned, darkened.
- Don't overload the frying tank.
- Don't fill the basket more than half full.
- Don't shake breaded items over fryer.
- Don't salt items over fryer.
- Don't introduce water to fryer.
- Don't thaw frozen foods before frying.



## Operating the Fryer

1. Check E-Stop Button, make sure it is in the OUT position.
2. Fill the tank to the minimum oil level with cooking oil.

**IMPORTANT:** Cooking oil expands upon heating. To safely bring the oil level up to the maximum fill level, carefully add additional increments of oil as it heats until it reaches the maximum fill line. **DO NOT over fill the tank, as overfilling could result in a dangerous situation.**

3. Set the Temperature Control to the desired cooking temperature. The Pilot Light will turn ON, and remain lit until the fryer has reached the cooking temperature.
4. Once oil is at maximum level and the red Pilot Light goes OFF, fryer is ready for use.
5. To help maintain oil quality, periodically skim off excess batter (food) particles.

## Shutdown Procedure and Draining the Tank

1. Once frying is complete, turn Temperature Control OFF.
2. Remove any forms, the thermometer, and allow the unit to cool completely. It is recommended to press the E-Stop Button IN to cut all power to the unit when not in use.
3. a. If storing the oil for reuse, cover the oil tank with a clean, dry tank cover. (Be sure the oil has cooled before applying tank cover.)  
b. If moving the unit from its current location, the oil must be drained. **DO NOT move this unit when filled with oil!** Allow hot cooking oil to cool below 140°F before attempting drain the unit.
4. To drain the unit, have an appropriate container in place to receive the oil.
5. With the drain valve CLOSED, remove the drain plug.
6. Slide the safety collar up on the drain valve handle, then OPEN the drain valve to empty the cooking oil from the fryer tank.
7. For unit cleaning instructions, see Care and Cleaning section.

## Care and Cleaning

	<b>⚠ DANGER</b>
	Machine must be properly grounded to prevent electrical shock to personnel. <b>DO NOT immerse in water.</b> DO NOT clean appliance with a water jet. Always unplug the equipment before cleaning or servicing. <span style="float: right;">025_111616</span>

	<b>⚠ WARNING</b>
	Hot surface and hot oil inside unit. DO NOT touch! Always allow unit to cool before cleaning, servicing, or draining oil. <span style="float: right;">026_031914</span>

Good sanitation practice demands that all food preparation equipment be cleaned regularly (only use non-toxic, food grade cleaners). A clean looking, well-kept machine is one of the best ways of advertising your product.

Follow the directions below to clean and sanitize the unit each day after use.

1. With the machine OFF, unplug the unit and allow it to cool before attempting to clean it after use.  
**DO NOT move this unit when filled with oil!** Allow hot cooking oil to cool below 140°F before attempting drain the unit.
2. Make sure to clean all pans/accessories in order to sanitize them before each use.
3. Make sure the drain valve is securely closed and the drain plug is fully tightened into place, then fill the tank with water to the MINIMUM oil level. **DO NOT FILL above the minimum oil level or equipment damage may occur.**
4. Add appropriate amount of dish soap. [To deep clean a tank which has a build-up of cooking oil, instead of soap, add appropriate amount of Gold Medal's Heat'n Kleen (Item No. 2095) per amount of water used (see Heat'n Kleen product instructions)].
5. Bring solution to a boil (**DO NOT heat above 250°F**), then turn the machine OFF, unplug the unit and allow solution to cool to below 100°F.
6. Once cooled, drain and remove all solution.
7. Clean the outside of the unit with a soft cloth, dampened with soap and hot water.
8. Wipe the stainless steel parts with a clean cloth and cleaner designed for stainless steel, such as Gold Medal Watchdog Stainless Cleaner (Item No. 2088).  
**DO NOT** use oven cleaners or abrasive materials as they will damage parts of the machine.
9. Thoroughly dry the unit after cleaning, including inside any drain valves.







## TROUBLESHOOTING



Issue	Possible Cause	Solution
<b>Unit Does Not Power ON</b>	<p>A. No power to unit</p> <p>B. Power Head placement</p> <p>C. E-Stop Button</p> <p>D. High Limit Reset</p>	<p>A. Check that the unit is plugged into the wall outlet. See Electrical Requirements section for electrical specifications.</p> <p>B. Check placement of Power Head on the tank. If the power head is not securely seated on the tank the head will not power on.</p> <p>C. Ensure the E-Stop Button is in the operate position (the switch must be in the OUT position to operate the unit).</p> <p>D. Check to see if the High Limit Reset is tripped. The High Limit Control can only be reset after the fryer has cooled to normal operating temperatures. If reset, then it trips again, contact Qualified Service Personnel to service the unit.</p>
<b>Slow or Uneven Oil Heating</b>	<p>A. Heating Element</p> <p>B. Center Head on Tank</p> <p>C. Product Cooking Issues</p> <p>D. Slow Cook Times</p>	<p>A. Low supply voltage, contact Qualified Service Personnel.</p> <p>B. For maximum heating capabilities, center the power head on the tank.</p> <p>C. Reference the Important Operating Information and Quality Control Tips section located in the Operating Instructions.</p> <p>D. If machines are operated at 208 Volts, the machine voltage will be 80% of full wattage. For example: Model 8048D at 230 Volts is rated 3000 Watts. If operated at 208 Volts the wattage will be 2400 Watts (multiply <math>.08 \times 3000 = 2400</math> Watts).</p>
<b>High Limit Control Tripping (powers down machine)</b>	<p>A. Oil level too low</p> <p>B. Malfunction in Heat Control</p> <p>C. A heating relay stuck closed or Heat Control failure</p>	<p>A. Check that the oil level has not fallen below the minimum oil level. <b>DO NOT</b> operate this unit with the oil below the minimum oil level (see Filling the Tank with Oil section).</p> <p>B. Insert a thermometer in the tank of oil and check the temperature of the oil in the tank against the temperature of the Temperature Control Dial. A difference in the temperatures will indicate possible control malfunction. The High Limit Control will trip above 440°F. Contact Qualified Service Personnel to service the unit.</p> <p>C. If the relay is stuck closed the unit will not regulate temperature and the High Limit will trip to prevent overheating. Contact Qualified Service Personnel to service the unit.</p>







# MAINTENANCE INSTRUCTIONS

	 <b>DANGER</b>
	<p>Machine must be properly grounded to prevent electrical shock to personnel. Failure to do so could result in serious injury, or death. DO NOT immerse any part of this equipment in water. DO NOT use excessive water when cleaning. Keep cord and plug off the ground and away from moisture. Always unplug the equipment before cleaning or servicing. Make sure all machine switches are in the OFF position before plugging the equipment into the receptacle.</p> <p style="text-align: right; font-size: small;">008_051514</p>

	 <b>DANGER</b>
	<p>Improper installation, adjustment, alteration, service, or maintenance can cause property damage, injury, or death. Any alterations to this equipment will void the warranty and may cause a dangerous condition. This appliance is not intended to be operated by means of an external timer or separate remote-control system. NEVER make alterations to this equipment. Read the Installation, Operating, and Maintenance Instructions thoroughly before installing, servicing, or operating this equipment.</p> <p style="text-align: right; font-size: small;">014_020416</p>

	 <b>WARNING</b>
	<p>Hot surface and hot oil inside unit. DO NOT touch! Always allow unit to cool before cleaning, servicing, or draining oil.</p> <p style="text-align: right; font-size: small;">026_031914</p>

	 <b>WARNING</b>
	<p>No user serviceable parts inside. Refer servicing to qualified service personnel.</p> <p style="text-align: right; font-size: small;">011_051514</p>

	 <b>CAUTION</b>
	<p>THE FOLLOWING SECTIONS OF THIS MANUAL ARE INTENDED ONLY FOR QUALIFIED SERVICE PERSONNEL WHO ARE FAMILIAR WITH ELECTRICAL EQUIPMENT. THESE ARE NOT INTENDED FOR THE OPERATOR.</p> <p style="text-align: right; font-size: small;">027_010914</p>





---

## ORDERING SPARE PARTS

1. Identify the needed part by checking it against the photos, illustrations, and/or parts list. (General images may be used in manual for reference only.)
2. Use only approved replacement parts when servicing this unit.
3. When ordering, please include part number, part name, and quantity needed.
4. Please include your model number, serial number, and date of manufacture (located on the machine nameplate/data plate) with your order.
5. Address all parts orders to:

Parts Department  
Gold Medal Products Co.  
10700 Medallion Drive  
Cincinnati, Ohio 45241-4807

Or, place orders by phone or online:

Phone: (800) 543-0862  
(513) 769-7676  
Fax: (800) 542-1496  
(513) 769-8500  
E-mail: [info@gmpopcorn.com](mailto:info@gmpopcorn.com)  
Web Page: [gmpopcorn.com](http://gmpopcorn.com)



## Cabinet Exterior – Parts Breakdown

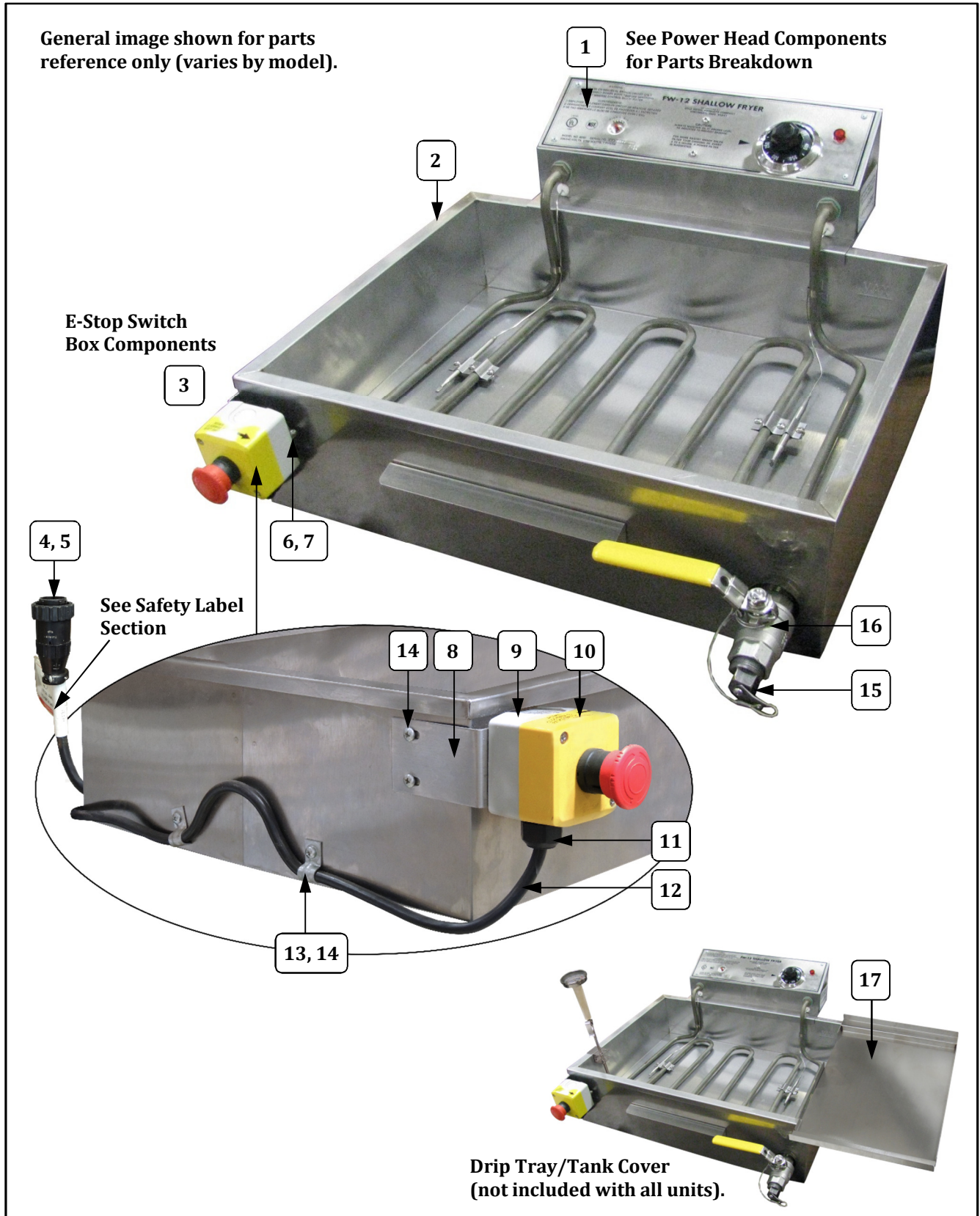



## Cabinet Exterior – Parts List

Item	Part Description	Part Number										
		8047D	8048D	8049D	8050D	8051D	8066	8068	8068FL	8073	8073BF	8075
1	POWER HEAD ASSY	8060	8061	8063	8064	8062	8067	8069	8069FL	8074	8074BF	8067
2	TANK & CABNT ASSY W/DRAIN	89056	89056	89230	89330	89230	89330	89812	89866	89857	89857	89824
3	SWITCH BOX COMPONENTS (incls Items 4-12 below)	89887	89887	89887	89887	89887	89887	89887	89887	89887	89887	89887
4	PLUG	49220	49220	49220	49220	49220	49220	49220	49220	49220	49220	49220
5	CABLE CLAMP	49221	49221	49221	49221	49221	49221	49221	49221	49221	49221	49221
6	8-32 ACORN NUT SS	12385	12385	12385	12385	12385	12385	12385	12385	12385	12385	12385
7	8-32 X 1/2 PH PAN W/SEMS	47124	47124	47124	47124	47124	47124	47124	47124	47124	47124	47124
8	SWITCH BRACKET	69828	69828	69828	69828	69828	69828	69828	69828	69828	69828	69828
9	E-STOP CONTROL STATION	69829	69829	69829	69829	69829	69829	69829	69829	69829	69829	69829
10	SAFETY SWITCH LABEL	77901	77901	77901	77901	77901	77901	77901	77901	77901	77901	77901
11	CORDGRIP, STRAIGHT	55234	55234	55234	55234	55234	55234	55234	55234	55234	55234	55234
12	CABLE ASSEMBLY	89889	89889	89889	89889	89889	89889	89889	89889	89889	89889	89889
13	WIRE CLIP, 3/8 IN.	55274	55274	55274	55274	55274	55274	55274	55274	55274	55274	55274
14	10-24 X 3/8 PAN HD PH T23	38111	38111	38111	38111	38111	38111	38111	38111	38111	38111	38111
15	DRAIN PLUG ASSEMBLY	89440	89440	89440	89440	89440	89440	89440	89440	89440	89440	89440
16	DRAIN VALVE	89014	89014	89014	89014	89014	89014	89014	89014	89014	89014	89014
17	DRIP TRAY/TANK COVER			89218	89218	89218	89225			89218	89218	89825



# Power Head Components – Front View – Parts Breakdown

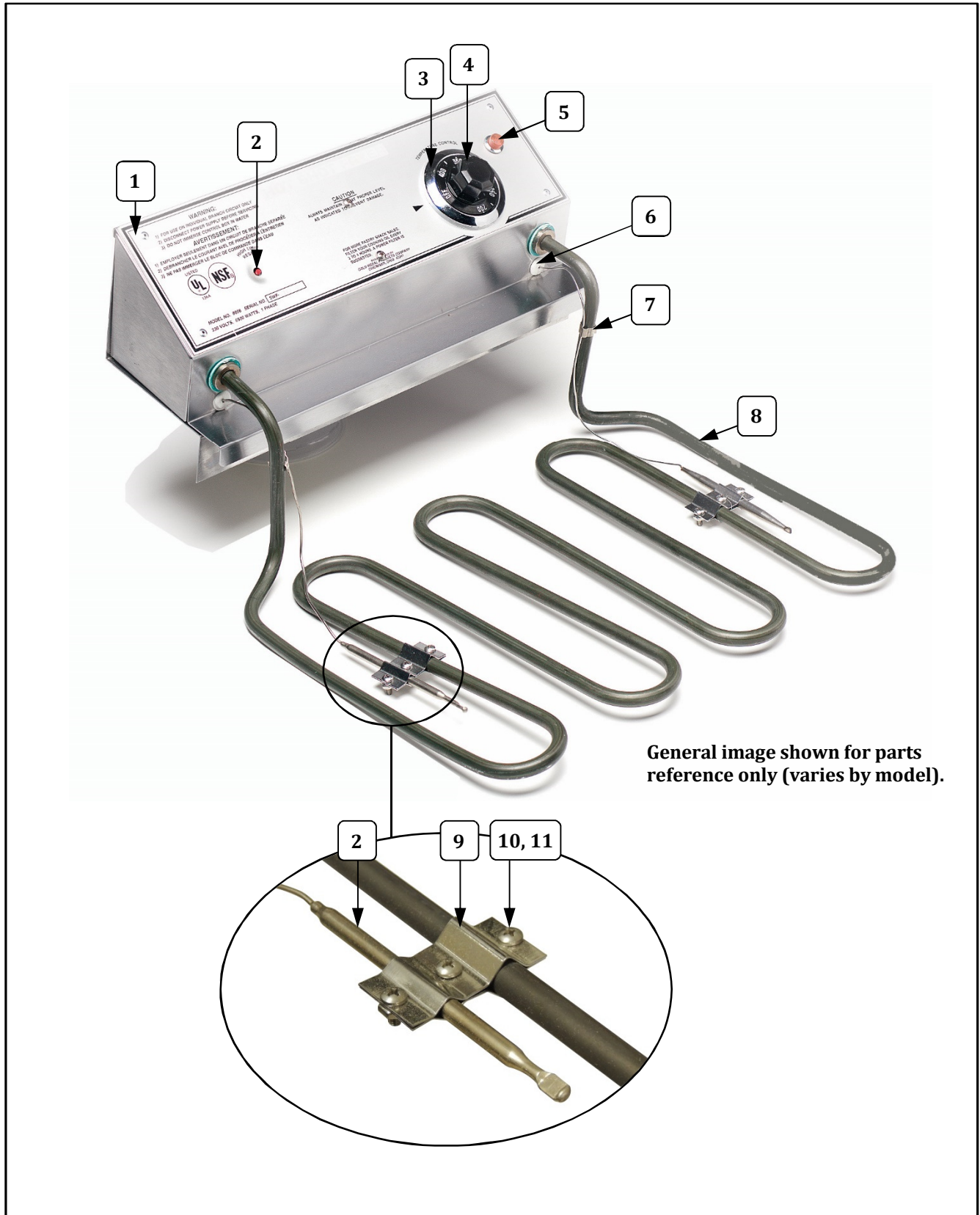

General image shown for parts reference only (varies by model).



## Power Head Components – Front View – Parts List

Item	Part Description	Part Number										
		8047D	8048D	8049D	8050D	8051D	8066	8068	8068FL	8073	8073BF	8075
1	POWER HEAD ASSY (Complete Assembly)	8060	8061	8063	8064	8062	8067	8069	8069FL	8074	8074BF	8067
2	HIGH LIMIT CONTROL/CAPI	89007	89007	89007	89007	89007	89007	89007	89007	89007	89007	89007
3	THERMOSTAT BEZEL	89006	89006	89006	89006	89006	89006	89006	89006	89006	89006	89006
4	THERMOSTAT KNOB	89005	89005	89005	89005	89005	89005	89005	89005	89005	89005	89005
5	PILOT LIGHT	41033	41032	41032	41032	41033	41032	41032	41032	41032	41032	41032
6	BLACK GROMMET	101069	101069	101069	101069	101069	101069	101069	101069	101069	101069	101069
7	CAPILLARY TUBE RETAIN	89018	89018	89018	89018	89018	89018	89018	89018			
8	HEAT ELEMENT 120V,1800W	89010				89324						
	HEAT ELEMENT 230V,3000W		89011									
	HEAT ELEMENT 230V,4400W			89204								
	HEAT ELEMENT 230V,5500W				89304					89201	89203	
	HEAT ELEMENT, 230V, 5750W							89807	89844			
	HEAT ELEMENT 230V, 6500W						89804					89804
9	CAPILLARY BULB RETAINER	89000	89000	89000	89000	89000	89000	89000	89000	89000	89000	89000
10	8-32 X 3/8 PAN HD PH M/S	12389	12389	12389	12389	12389	12389	12389	12389	12389	12389	12389
11	HEX NUT #8-32 STAINLESS	89129	89129	89129	89129	89129	89129	89129	89129	89129	89129	89129



## Power Head Components – Back View

General image shown for parts reference only (varies by model).

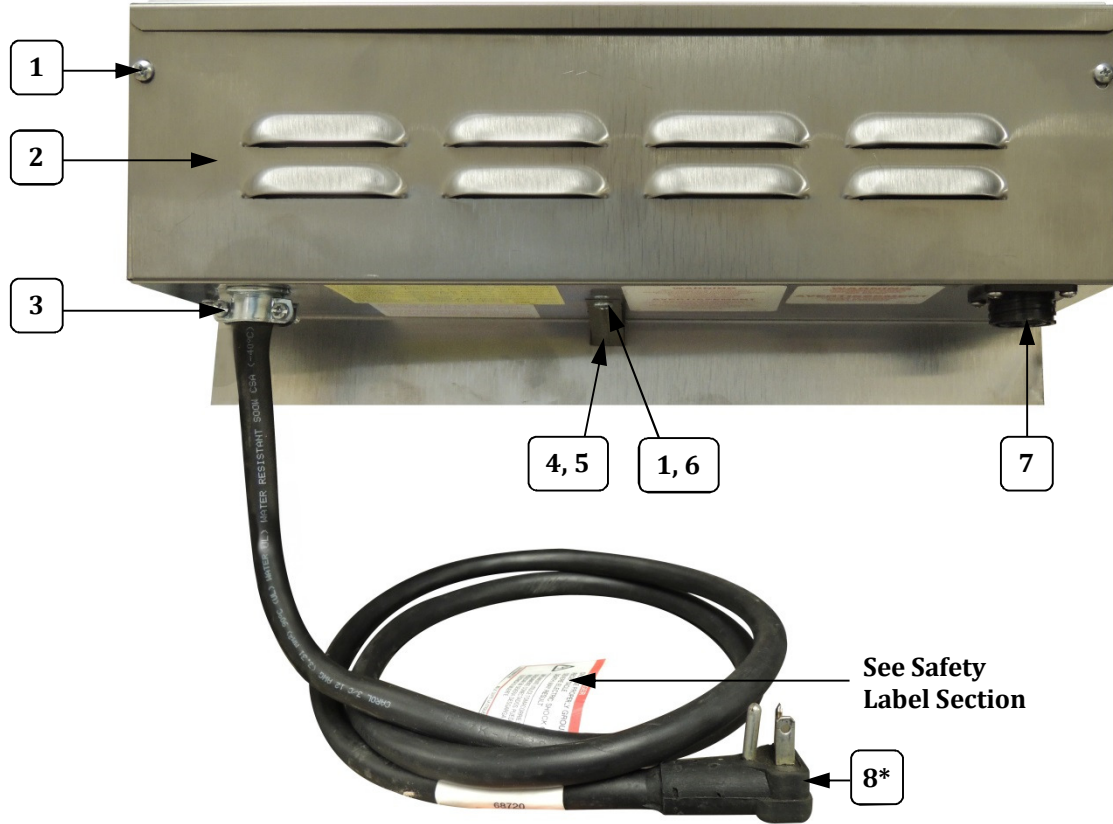

**\*CAUTION: If supply cord is damaged, it must be replaced by Gold Medal Products Co., its service agent, or similarly qualified persons in order to avoid a hazard.**

Item	Part Description	Part Number										
		8047D	8048D	8049D	8050D	8051D	8066	8068	8068FL	8073	8073BF	8075
1	SCREW #8-32X3/8 PAN HD PH	74141	74141	74141	74141	74141	74141	74141	74141	74141	74141	74141
2	REAR COVER CONTROL BOX	89019	89019	89326	89205	89326	89829	89838	89838	89205	89205	89829
3	STRAIN RELIEF	82227	89045	89017	89017	89045	82227	89045	89045	89017	89017	82227
4	ACTUATOR SWITCH BRKT	89039	89039	89039	89039	89039	89039	89039	89039	89039	89039	89039
5	SWITCH, LIMIT 15 AMP	89043	89043	89043	89043	89043	89043	89043	89043	89043	89043	89043
6	8-32 SERRATED FLANGE NUT	61151	61151	61151	61151	61151	61151	61151	61151	61151	61151	61151
7	SQUARE FLANGED RECEPTACLE	49224	49224	49224	49224	49224	49224	49224	49224	49224	49224	49224
8*	LEAD-IN CORD ASSY	89173	89172	89171	89170	89173	89169	89170	89170	89170	89170	89169



## Power Head Components – Interior View

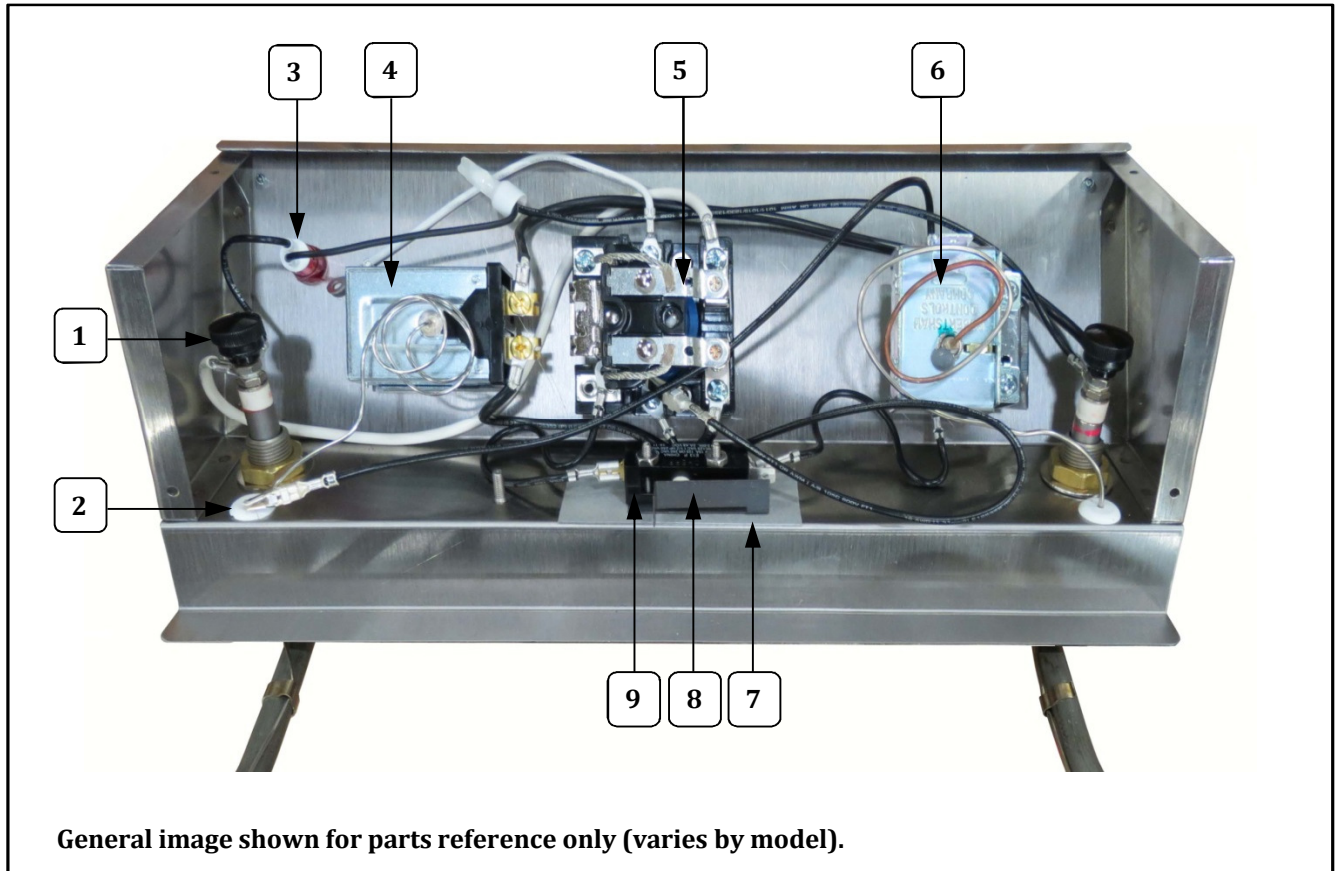

Item	Part Description	Part Number										
		8047D	8048D	8049D	8050D	8051D	8066	8068	8068FL	8073	8073BF	8075
1	BLACK KNOB #10-32	89012	89012	89012	89012	89012	89012	89012	89012	89012	89012	89012
2	BLACK GROMMET	101069	101069	101069	101069	101069	101069	101069	101069	101069	101069	101069
3	PILOT LIGHT	41033	41032	41032	41032	41033	41032	41032	41032	41032	41032	41032
4	THERMOSTAT/TEMP. CONTROL	89004	89004	89004	89004	89004	89004	89004	89004	89004	89004	89004
5	RELAY	55503	55503EX	89803	89803	55219	89803	55503EX	55503EX	89803	89803	89803
6	HIGH LIMIT CONTROL/CAP	89007	89007	89007	89007	89007	89007	89007	89007	89007	89007	89007
7	INSULATOR LIMIT SWITCH	89037	89037	89037	89037	89037	89037	89037	89037	89037	89037	89037
8	BRKT LIMIT SWITCH FRYERS	89038	89038	89038	89038	89038	89038	89038	89038	89038	89038	89038
9	SWITCH, LIMIT 15 AMP	89043	89043	89043	89043	89043	89043	89043	89043	89043	89043	89043



# Safety Labels

**1** FOR PARTS OR SERVICE CALL GOLD MEDAL PRODUCTS CO. SERVICE DEPARTMENT  
1-800-543-0862  
87935

**2** WARNING! CONTACT WITH THIS SURFACE WHILE THE APPLIANCE IS OPERATING MAY CAUSE BURNS  
AVERTISSEMENT! CONTACT AVEC CETTE SURFACE PENDANT LE FONCTIONNEMENT DE L'APPAREIL POURRAIT CAUSER DES BRULURES  
87087

**3** WARNING  
Do not operate until you have read and understand SAFE OPERATING INSTRUCTIONS furnished with this machine.  
For additional copies of instructions, write: MANUFACTURER  
AVERTISSEMENT  
Ne pas mettre en marche avant d'avoir lu et compris les INSTRUCTIONS POUR OPERATION SANS DANGER qui accompagnent cet appareil.  
Pour copies supplémentaires des instructions, écrivez à : FABRICANT  
47010

**4** WARNING  
DISCONNECT POWER BEFORE REMOVING ANY COVER  
AVERTISSEMENT  
COUPER LE COURANT AVANT D'ENLEVER TOUT COUVERCLE  
74119

**5** WARNING:  
1) DISCONNECT POWER SUPPLY BEFORE SERVICING  
2) DO NOT IMMERSE CONTROL BOX IN WATER  
AVERTISSEMENT:  
1) DÉBRANCHER LE COURANT AVEL DE PROCÉDER À L'ENTRETIEN  
2) NE PAS IMMERGER LE BLOC DE COMMANDE DANS L'EAU  
89036

**6** CAUTION . . . . . Disconnect power supply before servicing, cleaning or replacing lamps.  
CAUTION . . . . . Disconnect power supply before opening this compartment.  
PRECAUCION . . . . . desconectar la fuente de energia antes de reparar, limpiar o cambiar los focos.  
PRECAUCION . . . . . desconectar la fuente de energia antes de abrir este compartimento.  
ACHTUNG! . . . . . Vor Wartung, Reinigung oder Auswechsein von Lampen Strom abstellen!  
ACHTUNG! . . . . . Vor Öffnen dieses Faches Strom abstellen!  
ATTENTION . . . . . débranchez le fil électrique avant d'entretenir, de nettoyer ou de remplacer les ampoules.  
ATTENTION . . . . . débranchez le fil électrique avant d'ouvrir ce compartiment.  
87149

**7** DANGER  
ONLY USE PROPERLY GROUNDED RECEPTACLE  
SEVERE ELECTRIC SHOCK OR DEATH MAY RESULT  
UNICAMENTE UTILICE TOMACORRIENTES DEBIDAMENTE CONECTADOS PUEDE RESULTAR EN SEVERA DESGARGA ELECTRICA O MUERTE  
68720

**8** DANGER  
DO NOT GRAB BY THE CORD OR PULL. NE PAS DÉPLACER L'APPAREIL EN TIRANT SUR LE CORDON OU LA FICHE.  
KEEP ENTIRE AREA DRY.  
PLACER DANS UN ENDROIT ENTIEREMENT SEC  
SEVERE ELECTRIC SHOCK OR DEATH MAY RESULT  
DANGER DE DÉCHARGE ÉLECTRIQUE GRAVE  
POURRAIT CAUSER LA MORTI  
DO NOT TOUCH HOT SURFACE  
NE PAS TOUCHER LA SURFACE CHAUDE  
82840

**9** DANGER  
Never add water to hot oil, steam explosion may ensue spattering hot oil resulting in serious burns. Ensure tank is completely dry before adding oil.  
Hot oil is flammable - keep open flames away from hot oil, keep a fire extinguisher near. Use only fire extinguishers approved for grease, oil, & electric fires. DO NOT USE WATER ON A GREASE FIRE!  
BURN HAZARD! DO NOT TOUCH! Hot surfaces & hot oil present. Allow unit to cool before cleaning, servicing, or draining oil.  
Fryer to be operated on a level, stable surface. Maintain oil level between fill lines on inside of tank. Failure to do so could result in a dangerous situation.  
101096

## Power Head Labels

## Power Cord Label

## E-Stop Cord Label

## Tank Label

Item	Part Description	Part No.
1	SERVICE LABEL	87935
2	WARNING, SURFACE CONTACT	87087
3	LABEL SAFE OPERATING INST	47010
4	LBL WARN DISCONNECT POWER	74119
5	WARNING, DO NOT IMMERSE	89036
6	LBL CAUTION DISCONNECT PR	87149
7	WARNING LABEL CORD	68720
8	CONDUIT WARNING LABEL	82840
9	FRYER TANK SAFETY LABEL	101096





## Accessories

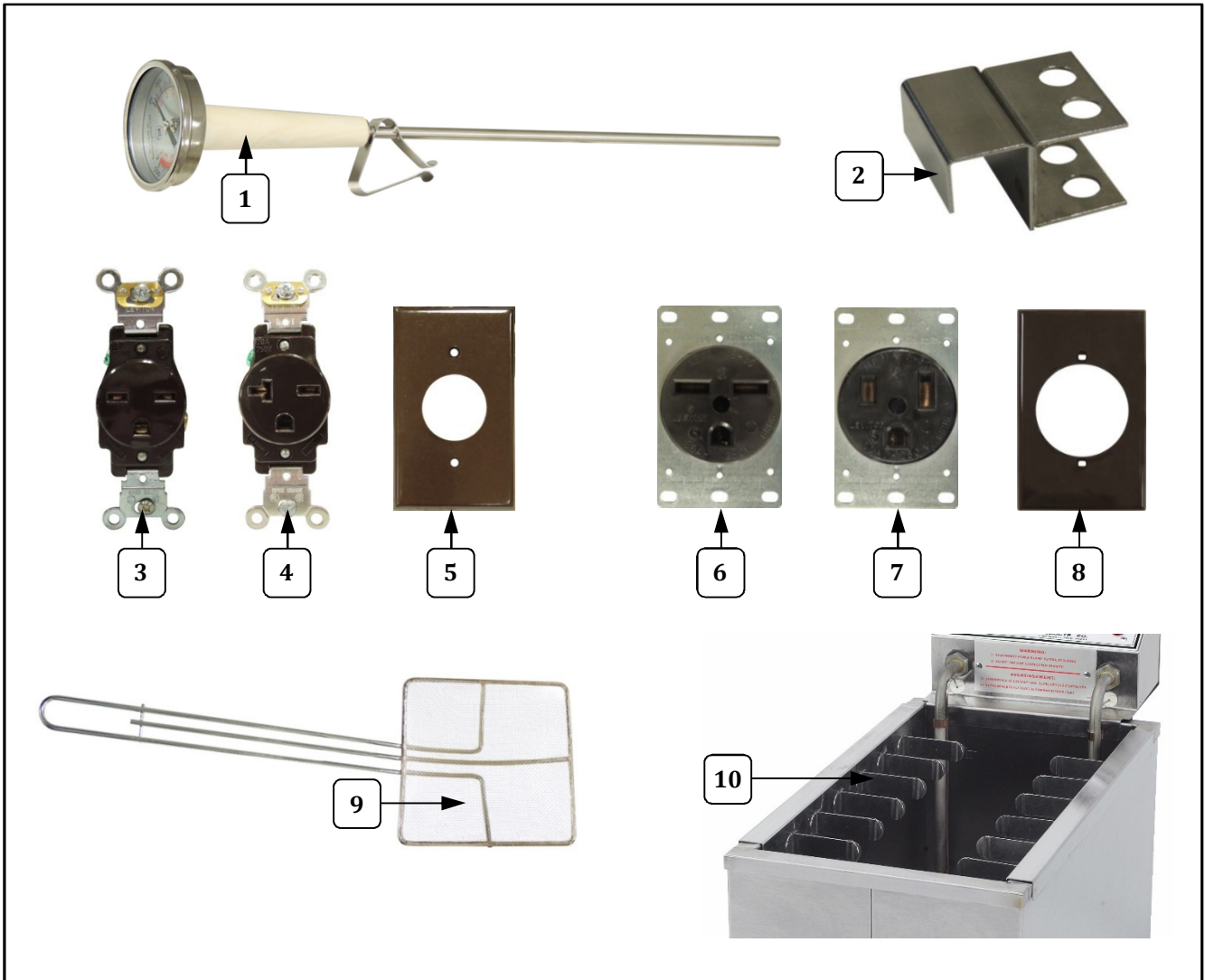

Item	Part Description	Part Number										
		8047D	8048D	8049D	8050D	8051D	8066	8068	8068FL	8073	8073BF	8075
1	DIAL TYPE THERMOMETER	4300	4300	4300	4300	4300	4300	4300	4300	4300	4300	4300
2	THERMOMETER BRACKET	89843	89843	89843	89843	89843	89843	89843	89843	89843	89843	89843
3	RECEPTACLE (15A)		89107									
4	RECEPTACLE (20A)			89224								
5	COVER PLATE		47605	47605								
6	RECEPTACLE 6-30R 30A 250V				89318			89318	89318	89318	89318	
7	RECEPTACLE 6-50R 50A 250V						89830					89830
8	RECEPTACLE COVER				47377		47377	47377	47377	47377	47377	47377
9	FINE MESH SKIMMER										8055	
10	SKEWER CLIP ASSY	89103	89103					89103	89103			



# Wiring Diagram

## Model No. 8049D, 80850D, 8051D, 8073, 8073BF, 8075

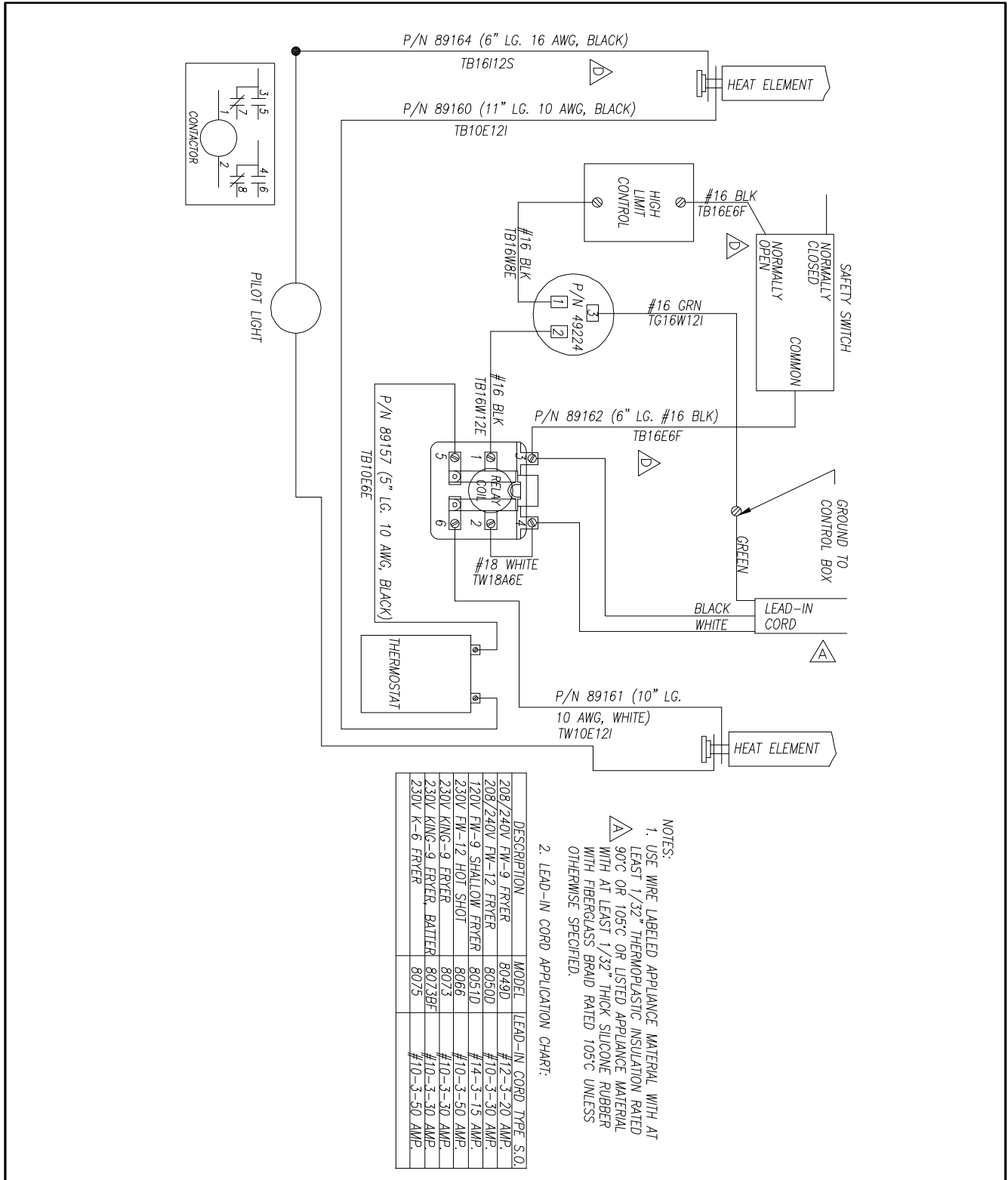



# Model No. 8047D, 8048D, 8049D, 8068, 8068FL

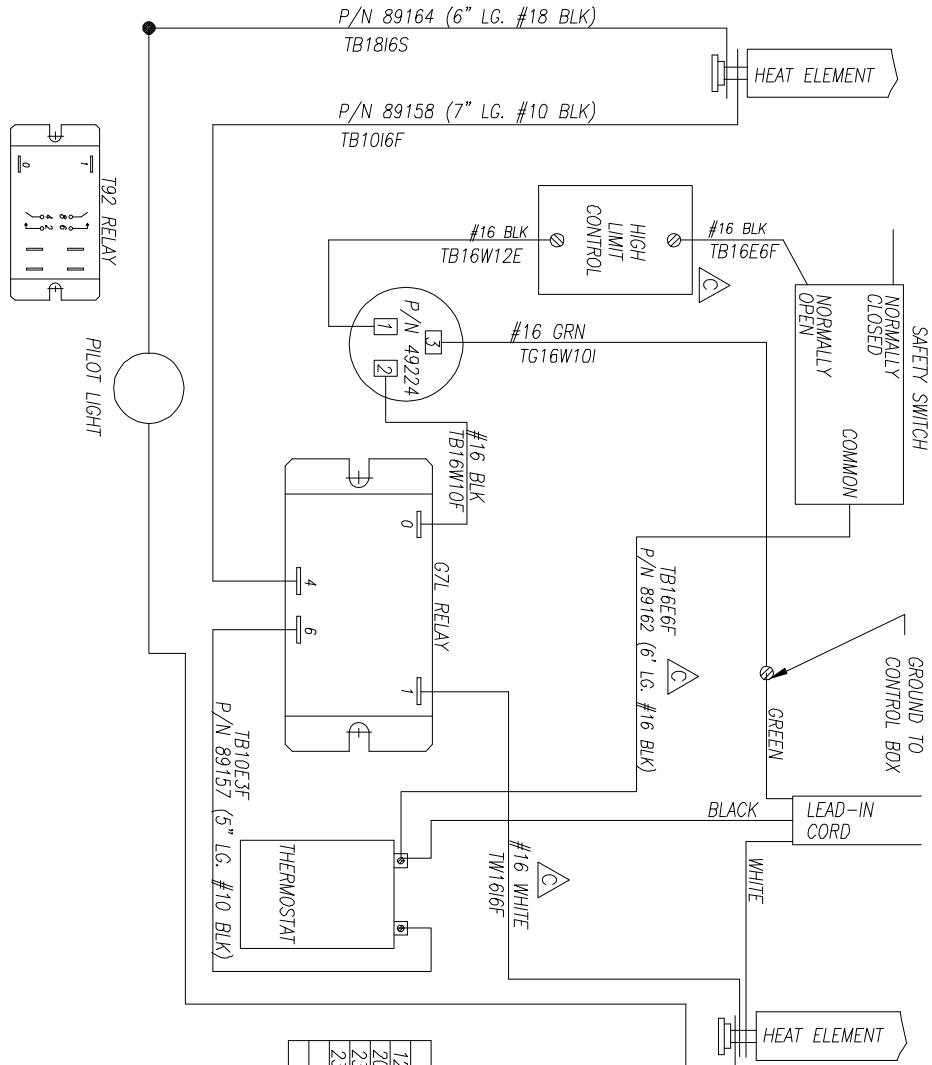

2. LEAD-IN CORD APPLICATION CHART:

DESCRIPTION	MODEL	LEAD-IN CORD TYPE	S.O.
120V SMALL FRYER	8047D	#14-3-15 AMP.	
208/240V SMALL FRYER	8048D	#14-3-15 AMP.	
230V KING DOG FRYER	8068	#10-3-30 AMP.	
230V FOOT LONG KING DOG	8068FL	#10-3-30 AMP.	

- NOTES:
1. USE WIRE LABELED APPLIANCE MATERIAL WITH AT LEAST 1/32" THERMOPLASTIC INSULATION RATED 90°C OR 105°C OR LISTED APPLIANCE MATERIAL WITH AT LEAST 1/32" THICK SILICONE RUBBER WITH FIBERGLASS BRAID RATED 105°C UNLESS OTHERWISE SPECIFIED.



## WARRANTY

Gold Medal Products Co. warrants to the original purchaser each item of its manufacture to be free of defects in workmanship and material under normal use and service. Gold Medal Products Co.'s obligation under this warranty is limited solely to repairing or replacing parts, f.o.b. Cincinnati, Ohio, which in its judgment are defective in workmanship or material and which are returned, freight prepaid, to its Cincinnati, Ohio factory or other designated point. Except for "Perishable Parts" on specific machines, the above warranty applies for a period of two (2) years from the date of original sale to the original purchaser of equipment when recommended operating instructions and maintenance procedures have been followed. These are packed with the machine. Parts warranty is two (2) years, labor is six (6) months.

THIS WARRANTY IS IN LIEU OF ALL OTHER WARRANTIES EXPRESSED OR IMPLIED, AND OF ALL OTHER OBLIGATIONS OR LIABILITIES ON OUR PART, INCLUDING THE IMPLIED WARRANTY OF MERCHANTABILITY. THERE ARE NO WARRANTIES WHICH EXTEND BEYOND THE DESCRIPTION ON THE FACE HEREOF. In no event shall Gold Medal Products Co. be liable for special, incidental or consequential damages. No claim under this warranty will be honored if the equipment covered has been misused, neglected, damaged in transit, or has been tampered with or changed in any way. No claim under this warranty shall be honored in the event that components in the unit at the time of the claim were not supplied or approved by Gold Medal Products Co. This warranty is effective only when electrical items have been properly attached to city utility lines only at proper voltages. This warranty is not transferable without the written consent of Gold Medal Products Co.

The term "Original Purchaser" as used in this warranty shall be deemed to mean that person, firm, association, or corporation who was billed by the GOLD MEDAL PRODUCTS CO., or their authorized distributor for the equipment.

THIS WARRANTY HAS NO EFFECT AND IS VOID UNLESS THE ORIGINAL PURCHASER FIRST CALLS GOLD MEDAL PRODUCTS CO. AT 1-800-543-0862 TO DISCUSS WITH OUR SERVICE REPRESENTATIVE THE EQUIPMENT PROBLEM, AND, IF NECESSARY, FOR INSTRUCTIONS CONCERNING THE REPAIR OR REPLACEMENT OF PARTS.

*NOTE: This equipment is manufactured and sold for commercial use only.*



**GOLD MEDAL<sup>®</sup> PRODUCTS CO.**

10700 Medallion Drive, Cincinnati, Ohio 45241-4807 USA

[gmpopcorn.com](http://gmpopcorn.com)

Phone: (800) 543-0862      Fax: (800) 542-1496  
(513) 769-7676              (513) 769-8500